

High Precision Analog Front End

FEATURES

- ▶ Analog input/output
  - ▶ Multichannel, 16-bit, 1 MSPS SAR ADC
    - ▶ 17 external voltage input channels
    - ▶ 4 TIA input channels
    - ▶ Internal channels: 11 IDAC monitor channels, 9 VDAC monitor channels, and 3 power monitor channels
    - ▶ Single-ended mode
  - ▶ IDACs
    - ▶ 11 low noise, 16-bit, IDAC outputs
      - ▶ Four channels either 0 mA to 150 mA or 0 mA to 200 mA
      - ▶ Seven channels 0 to 20 mA or, 0 to 50 mA channels
  - ▶ VDACs: Nine 16-bit output VDAC channels
    - ▶ Channel 0, Channel 1, Channel 3, and Channel 4: 0 V to 5 V, 150 Ω
    - ▶ Channel 2 and Channel 5 to Channel 8: 0 V to 5 V, 1 kΩ
  - ▶ On-chip voltage reference, 2.5 V
- ▶ SPI interface up to 40 MHz
- ▶ Power
  - ▶ Multiple supplies
    - ▶ AVDDx for VDACs and ADC to 5 V
    - ▶ 1.65 V to AVDDx – 0.5 V for PVDD\_IDACx
- ▶ Packages and temperature range
  - ▶ 4.5 mm × 4.6 mm, 100-ball WLCSP
  - ▶ Fully specified for –40°C to +125°C (T<sub>JA</sub> operation)

APPLICATIONS

- ▶ Optical communication modules

FUNCTIONAL BLOCK DIAGRAM

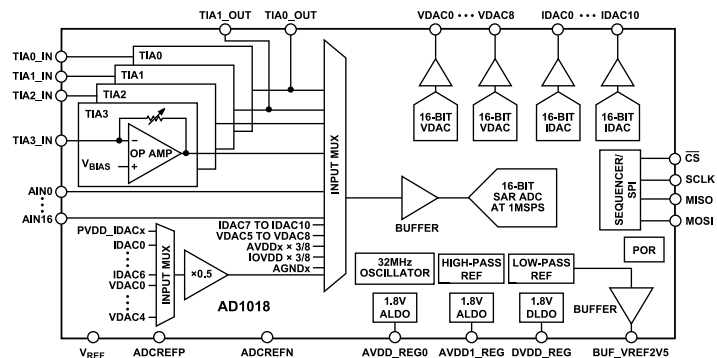

Figure 1.

For more information about the AD1018, contact Analog Devices, Inc., at [InfoOpticalNetwork@analog.com](mailto:InfoOpticalNetwork@analog.com).

Rev. Sp1

DOCUMENT FEEDBACK

TECHNICAL SUPPORT

Information furnished by Analog Devices is believed to be accurate and reliable "as is". However, no responsibility is assumed by Analog Devices for its use, nor for any infringements of patents or other rights of third parties that may result from its use. Specifications subject to change without notice. No license is granted by implication or otherwise under any patent or patent rights of Analog Devices. Trademarks and registered trademarks are the property of their respective owners.

---

**NOTES**